



User manual

EZRider

 **Convaid**
by Etac

UG1201-ENG-Rev.03 2024-11-19



www.etac.com

**UK
CA**



Customer Service Support

Toll Free: 1-844-US Mobility (844-876-6245)

Phone: (310) 618-0111

Fax: (310) 618-8811

Email: convaidsales.us@etac.com

International Email: international.convoid.us@etac.com

Website: www.etac.com

Technical assistance or repair information hours are:

Monday - Friday, 6 a.m. to 4:30 p.m. PST

Before Calling:

Please fill in the following. Customer Service will be able to help you more quickly if the information indicated below is readily available.

Serial number of chair: _____

Model of chair: _____

Date purchased: _____

Notice:

The information contained in this document is subject to change without notice.

No part of this document may be photocopied, reproduced, transmitted, transcribed, stored in a retrieval system or translated to another language or computer language, in any form or by any means, electronic, mechanical, magnetic, optical, chemical, manual or otherwise without the prior written consent of Convoid.

Use only Convoid accessories and parts on Convoid products. Convoid parts are not interchangeable with other manufacturers' products. Replace any worn parts immediately.

Table of Contents

Product Overview

Definition of Symbols	1
General Cautions	3
Overview	7
Specifications	8

Chair Setup and Adjustment

Contents in the Box.	10
How To Remove Chair from Box.	10
Preparing the Chair for Use	10
Tools Required.	10
Unfolding	11
Folding.	12
Lifting/Carrying.	13

Fitting Guide

Seat Back Height	14
Seat Width.	14
Seat Depth	15
Seat Depth Tube Replacement	15
Attaching Support Strap for Seat Extension Tubes.	16
Two-Piece Seat	16

Wheels

Wheel Options.	17
Quick Release Wheels	18
Anti-Shimmy Adjustment	19
Locking and Unlocking.	1

Operating Instructions

Three-Point Pelvic Belt	21
H-Harness with Padded Covers	22
Footplate Height Adjustment	23
Angle Adjustable Footplates.	24
Footplate Depth Adjustment	25
Caster Locks	25
Calf Panel	25

Accessories

Full Torso Swing-Away Support Vest 26

Lateral Thigh Support (Adductor)..... 26

Medial Thigh Support (Abductor)..... 26

Padded Headwings..... 27

Headrest Extension..... 27

Height Adjustable Flip-Up Armrests..... 28

Occi Headwing..... 28

5-Point Harness 29

Adjusting the Pelvic Stap 30

Adjusting the Crotch Strap 30

Seat Cushions..... 31

Fitting..... 32

Caution 32

Headrest Cover (Canopy) 33

Heavy Duty Reinforced Upholstery..... 34

Reducer Seat Insert 34

Rear Anti-Tip Tubes 34

Utility Bag..... 35

Transit Models

Transit Option 36

Transit Mode Instructions..... 37

Recommended Clear Zones In Vehicle 38

Providing Clear Space & Padding 38

Proper Use of Equipment 40

Restraining the Wheelchair Occupant..... 43

Using Postural Belts & Supports 44

Trays & Other Wheelchair Components..... 45

WTORS Manufacturers..... 45

Miscellaneous

Fabric Removal 46

Adjustable Tension Back 47

Important Information

Maintenance, Operating & Safety Instructions..... 48











Warranty Back Cover















READ BEFORE USE

Read the user's guide completely before use and fully understand its content. Familiarize yourself with the handling and functions of the product before use and practice them. Any caregiver that is going to operate this chair should also read the user's guide in full.

You are responsible for the safety of the user. The safety of the user could be affected if you do not follow the instructions in this user's guide. Nevertheless, not all possible circumstances and unpredictable situations can be covered by this user's guide. Reason, care, and circumspection are not features of the product; they are required of persons who use the product. If instructions are not clear and further explanation is necessary, please contact your Convaid provider. If you do not follow all instructions and warnings, serious injury or damage to the chair may occur. The latest version of all instructions and product safety notices are available on the Convaid website (www.etac.us.com) and can be printed in larger sizes. Additional video instructions are also available for reference purposes.

Definition of Symbols

	<p>Indicates the medical device manufacturer.</p>		<p>Indicates a medical device that need to be consulted with the instruction for user.</p>
	<p>Indicates the date when the medical device was manufactured.</p>		<p>This symbol is a mandatory marking for devices entering the European market to indicate conformity with the essential health and safety requirements set out in European Directives. The symbol may be accompanied by a four-digit identification number of the notified body. The vertical dimensions may not be less than 5 mm high.</p>
	<p>Indicates the Authorized representative in the European Community.</p>		
	<p>Indicates the manufacturer's catalogue number so that the medical device can be identified.</p>		<p>To indicate the entity importing the medical device into the locale</p>
	<p>Indicates the manufacturer's serial number so that a specific medical device can be identified.</p>		<p>To indicate the entity distributing the medical device into the locale</p>
	<p>To indicate that caution is necessary when operating the device or control close to where the symbol is placed, or to indicate that the current situation needs operator awareness or operator action in order to avoid undesirable consequences.</p>		

	This symbol indicates a wheelchair which cannot be used in motor vehicle as vehicle seat. This wheelchair does not comply with WC19 (RESNAWC-4:2012 for ISO7176-19:2008) and cannot be used as a vehicle seat to transport the user in a vehicle.		This symbol indicates conformity with RESNA WC-4 Section 19 requirements.
	The symbol indicates a wheelchair which can be used in motor vehicle as vehicle seat. This wheelchair complies with WC19 (RESNAWC-4:2012 and ISO 7176-19:2008) and can be used as a vehicle seat to transport the user in a vehicle.		Medical Device
	This symbol indicates the position of an anchor point when using a 4-point tie down system (WTORS) during transit.		Unique Device Identifier
	This symbol indicates correct lifting points for safe moving and handling.		To identify the country of manufacture of products.
	This symbol indicates potential finger entrapment.		Maximum washing temperature 60°C (140°F). Mild Process
	This symbol is mandatory for products entering the United Kingdom to indicate it is compliant with all their regulatory requirements		Do not bleach.
			Do not iron.
			Do not tumble dry.
			This symbol is mandatory for products entering Brazil to indicate it is compliant with all their regulatory requirements

CHOOSE THE RIGHT CHAIR & SAFETY OPTIONS

There are several options available to meet the needs of the wheelchair user. Make sure that your (and your health care provider's) choice of chair and other added options takes into account the user's comfort, positioning, physical limitations, and hazards that may be encountered during daily use.

Operating the manual wheelchair outside of the recommendations provided by the manufacturer can lead to a dangerous situation.

 The wheelchair is not suitable for jogging, running, skating or similar activities. Swiveling front wheels tend to wobble at higher speeds and can cause a sudden stop, and the wheelchair can tip over. Use the wheelchair only at regular walking speed. Under no circumstance should you let go of the push handle while pushing.

The durability of this product is five years when it is used with proper care and maintenance according to the user's guide.

General Cautions

Intended Use

The Convaid EZRider is an attendant-propelled device, its intended function and use is to provide mobility to children to adults suffering from congenital or traumatic brain damage, degenerative or other physical handicaps that result in the lack of coordination or control, muscle weakness or paralysis.

Device Description

The EZRider models are attendant propelled, manual wheelchairs. They are lightweight, compact, folding wheelchairs with tubular frames with a collapsible design for easy transport and stowage. The chairs are designed with smaller, rotating front casters for maneuverability with larger fixed wheels in the rear. The EZRider chairs has options for positioning and support including but not limited to belts, harnesses, trays.

The EZRider has an available transit option that is identical to the non-transit models with the exception of tie-down anchors and required labeling for use as seating in motor vehicles.

Suitable Environment

The chair is intended for both indoor and outdoor use. If the chair is used in the rain, the excess water should be wiped off with a soft cloth. If the chair is splashed with mud or corrosive substances like salt water or road salt, the chair should be washed clean with water, wiped dry and a hypoallergenic and biodegradable lubricant reapplied to the moving parts. The chair should never go into seawater, as it will corrode areas that cannot be washed clean. When going from outside to inside, clean any excess dirt or mud from the wheels to prevent soiling of inside environment.

In case of an adverse event occurred in relation to the device incident should be reported to your local dealer and national competent authority in a timely manner. The local dealer will forward information to manufacturer.



CAUTION: Prior to occupant use:

- The operator/caregiver must read and understand this manual prior to operating this equipment. If you are unable to understand any part of this manual, contact your supplier for assistance.
- Keep packaging material away from children. Plastic packaging presents danger of suffocation.
- Make sure that the chair operates properly. Repair any problems before use.



- Do not use the chair unless it has proper tire pressure (front 36 psi/rear 30 psi, 248kPa/200kPa, 2.5BAR/2.0BAR). Do not overinflate the tires. Failure to follow these instructions may cause the tire to explode and cause harm. Tire size and maximum pressure are listed on the wheel.
- Always verify that the quick release axles are locked so that the back wheels do not come off. You will hear a “click” when wheel locks into place.
- Be aware of newly created sharp edges.
- Frequently inspect the adjustments on the frame and the positioning accessories.
- Do not ignore minor malfunctions and maintain the chair in good operating condition.
- Inspect the wheel locks (brakes) regularly and adjust as needed.
- The EZRider could lose its flame-resistant characteristics when using after-market seating or cushions.
- Do not use chair after occupant has outgrown it.



CAUTION: For occupant safety during use:

- The chair is only intended to carry one user at a time. Do not carry more than one user at a time.
- The weight capacity carried by the EZRider chair must never exceed the total weight capacity of the chair (maximum occupant size plus any items carried).
- Always secure the user with belt first, before making any other adjustments.
- The seat belt should be used at all times.
- Do not strap the user too tight. Straps should not interfere with breathing or circulation.
- Do not leave the user unattended even when he/she is strapped in and the wheel locks are engaged.
- Always apply the wheel locks before letting go of the chair. Never remove or place the user without engaging the wheel locks.
- Do not use the footplates for weight support during exit and entry of the chair.
- Always watch for obstacles and avoid them as often as possible.
- When going up a curb or step, face forward and tilt the chair back to lift the front wheels over the curb. Move forward and lift the rear wheels over the curb.





- When going down a curb, approach the curb backwards. Lower the rear wheels down the curb and continue backwards, taking the weight off the front wheels so they can be gently lowered.



- When transferring user to or from chair, apply foot wheel locks.



- Maintain control of the chair at all times while going up/down ramp.
- Avoid steep slopes, particularly with a heavy occupant. If in doubt, do not proceed unless a third party is present to help maintain control of chair.
- Do not attempt to take occupied chair up or down stairs, escalators, steep inclines, icy or slippery surfaces.

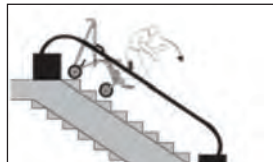

- Do not go up or down stairs without the assistance of another person or with the user in the chair. If devices such as ramps or elevators are available, please use them. If they are not available, then the chair should be carried over the obstacle by two people without the user in the chair.



- Maintain control of the chair at all times while going up/down ramp. Avoid steep slopes, particularly with a heavy occupant. If in doubt, do not proceed unless a third party is present to help maintain control of chair.



CAUTION: To prevent tipping:

- The use of anti-tip tubes should be used if the user's weight is less than 50lbs (22.7kg)
- Do not hang items from the push handle to avoid tipping.



- Be sure that the user does not lean out of the chair too far when reaching for objects in front, to the side, or behind the chair. A shift in the center of gravity might cause the chair to tilt or tip over.
- If front edge of seat is at or forward of the point where tires touch the floor, avoid using front of seat tubes for support during entry or exit from chair to prevent tipping.

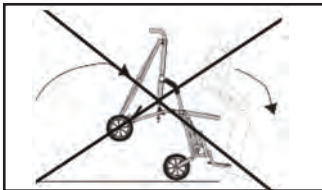

CAUTION: When using the chair in transit:

- If and whenever possible and feasible, the rider should transfer out of the chair and into an approved vehicle seat and passenger restraint system. However, if a transfer is not possible, use only designated chairs in a moving vehicle which contain the Wheelchair Tie-down and Occupant Restraint System (WTORS) following the requirements of SAE J2249. Follow tie-down harness manufacturer's instructions carefully and refer to Transit Section for specifics.
- Positioning belts should never be used as a safety restraint device in a motor vehicle when transporting the chair with an occupant. An additional WC19 (ISO 7176- 19) compliant automotive type seat belt is required when the chair is used in transport vehicles.
- A five-point harness should be used for occupant weight less than 51lb (23kg).
- All accessories must be removed from the chair and secured separately.

In case of an adverse event occurred in relation to the device incident should be reported to your local dealer and national competent authority in a timely manner. The local dealer will forward information to manufacturer.

Overview

One Piece Height Adjustable Push Handle

Never leave occupant unattended. Failure to read and follow user guide instructions could result in serious injury. To obtain a replacement user's guide email sales.us@convaid.com or call 844-876-6245.

Chair Warning Label



Serial number label



ANVISA Label
(Brazil Only)

290 mm x 64 mm
Rear Solid Wheels

191 mm x 51mm
Front Solid Wheels



Packaging label
(reference)

Self-Tensio®
Seat Support

Transit Anchor
(Option)



Transit Anchor
Logo Sticker

Removable Angle Adjustable
Swing-Away Footplates

Specifications

EZRider measurements	EZ 12	EZ 14	EZ 16	EZ 18
 Seat width	12" / 305mm	14" / 356mm	16" / 406mm	18" / 457mm
 Seat depth	9-14" / 228 - 356mm	11-16" / 279 - 406mm	12-17" / 304 - 431mm	14.5-19.5" / 368 - 495mm
 Seat back height	21" / 533mm (C) 19" / 482mm (T)	24" / 609mm (C) 22" / 558mm (T)	26" / 660mm (C) 24" / 609mm (T)	27" / 685mm (C) 25" / 635mm (T)
 Seat to floor	19" / 482mm	20" / 508mm	20" / 508mm	21.5" / 546mm
 Seat to back angle	100°	100°	100°	100°
 Seat angle	10°	10°	10°	10°
 Overall height	38" / 965mm	38.5" / 978mm	40" / 1016mm	37" / 940mm
 Overall length	36" / 914mm	37.5" / 953mm	43.5" / 1105mm	48" / 1219mm
 Overall width	21.5" / 546mm	23" / 584mm	26" / 660mm	26" / 660mm
 Folded length	44.5" / 1130mm	46" / 1168mm	48" / 1219mm	45.5" / 1155mm
 Folded width	14" / 356mm	13.5" / 343mm	14" / 356mm	14.5" / 368mm
 Folded height	17.5" / 445mm	18" / 457mm	17" / 432mm	15.5" / 394mm
 Headrest extension height	8" / 203mm	8" / 203mm	8" / 203mm	10" / 254mm
 Shoulder strap height	11-17" / 279-432mm	14-20" / 356-508mm	15-21" / 381-533mm	16-22" / 406-559mm
 Seat to footplate	3-20" / 76-508mm	3-21" / 76-533mm	3-22" / 76-559mm	3-22" / 76-559mm
 Push handle adjustments	29.5-46.5" / 749-1181mm	29-47" / 737-1194mm	28-45" / 711-1143mm	N/A
 Weight capacity regular/transit	75/66 lbs / 34/30kg	100/100 lbs / 45/45kg	170/170 lbs / 77/77kg	250/170 lbs / 113/77kg
 Weight of chair without front rigging	25 lbs / 11kg	30 lbs / 14kg	30 lbs / 14kg	29 lbs / 13kg

EZRider Product Line



EZRider



EZRider 18

Chair Set Up & Adjustment

Contents in the Box

List of items included in the box:

- Mobility base and seating module
- Set (pair) of rear wheels
- User's Guide
- Accessories as ordered
- 5/32" Allen wrench

How to Remove Chair from Box

1. Place box flat on the floor.
2. Verify that package is in good shape and that no damage has occurred during shipping.
3. Remove the chair from the packaging material.
4. Check to make sure that your order is complete.

Preparing the Chair for Use

Once you have all components as ordered, the directions for use in this User's Guide will guide you through the process of preparing the chair for use.

Convaid recommends the initial fitting, adjustments, and setup take place with the help of your Convaid Representative and/or Convaid Service Dealer. However, if the instructions contained in this user's guide are followed carefully, a caregiver or attendant will be able to set up and assemble the chair.

Tools Required

- 5/32" Allen wrench
- 7/16" Wrench
- 3/8" Wrench
- Phillips Screwdriver

Unfolding

1. Unlock closure strap. **Fig 1**
2. Stand chair upright. **Fig 2**
3. Push down on seat and push handle to unfold. **Fig 3**
4. Push down on lock bar to lock in place **Fig 4**
5. Adjust push handle. **Fig 5**
6. Flip armrests down **Fig. 6**
7. Flip footplates down **Fig. 7**
8. Unlock wheel locks **Fig. 8**



CAUTION: Keep fingers free of folding mechanism..



Fig. 1



Fig. 2



Fig. 3



Fig. 4



Fig. 5



Fig. 6



Fig. 7



Fig. 8

Folding

1. Engage the wheel lock. **Fig 9**
2. Pull upward on locking bar on back of chair to unlock. **Fig 10**
3. Adjust one-piece adjustable push handle to upward position. **Fig 11**
4. Flip up armrests (if equipped). **Fig 12**
5. Flip footplates to the side. **Fig 13**
6. Grasp the push handle and the seat tube and pull up to bring sides together to fold **Fig. 14**
7. Lay chair flat on ground and push down for further closure. **Fig. 15**
8. Use closure strap to secure fold. **Fig.16**



CAUTION: Always properly secure the EZRider in a safe location when transporting as cargo in vehicle.



CAUTION: To prevent injury, keep hands clear of folding mechanism during folding.



Fig. 9



Fig. 10



Fig. 11



Fig. 12



Fig. 13



Fig. 14



Fig. 15



Fig. 16

Lifting/Carrying

1. To safely lift or carry the chair, hold it using both hands.
2. When chair is folded and locked: with one hand, hold by leg tube and with the other, hold by seat back tube. **Fig. 17**
3. When chair is open, hold leg tube with one hand and seat back tube with the other. Alternately, hold by leg tube and push handle. **Fig. 18, 19 & 20**



Fig. 17



Fig. 18



Fig. 19



Fig. 20



CAUTION: Do not use armrest to lift the chair.

Fitting Guide

Convaid's lightweight, folding chairs are designed to be more than just a convenient chair. Properly fitted, Convaid chairs will provide years of comfortable use. Order the correct size chair by first determining the user's height, weight and seating measurements. As your child grows, refer back to this Fitting Guide to adjust the dimensions of the chair.

Correct seating and positioning encourages good posture, which in turn aids circulation, breathing and digestion. Please take the time to properly adjust the chair to fit the user. If the user is not correctly positioned, check the accessories section of this user's guide to see if one or more of our accessories would help to facilitate posture or consult a physical therapist. Improper seating can cause problems. Please consult a physical therapist or doctor for additional guidance.

Seat Back Height



Seat back height varies according to chair type and seat width. Headrest extensions are available when extra height is needed to support the head.

To determine the seat back height, measure from the seat to the top of the shoulder or the upper part of the head. **Fig. 21**

Fig. 21

Seat Width

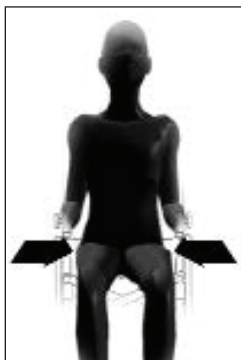

Proper seat width enables the user to sit comfortably and prevents problems from developing. While user is seated on a flat surface, measure from hip to hip. **Fig. 22**

The user should have enough room to prevent hips and thighs from rubbing against the frame. However, the chair should not be too wide or the user will slide around and posture could be affected.

The seat width measurement for the EZRider is taken from the actual seat width.

Fig. 22

Seat Depth



Fig. 23

Measure from the most posterior portion of the buttocks to the back of the knee. Subtract from that measurement 25 mm - 51 mm to allow adequate clearance between the seat and the back of the knee.

Fig. 23

To Change Seat Depth

1. Partially fold the chair to relieve fabric tension. Undo the hook and loop straps back panel of the two piece seat.
2. Grasp end of seat tube, depress spring button and move seat tube until spring button relocates into the desired hole.
3. Repeat for other side of seat. **Fig. 24**



Fig. 24

Seat Depth Tube Replacement

1. To change seat tubes or remove the seat tubes, press spring button. To install new seat tubes, press spring button and release when desired setting is achieved. Repeat for opposite side. **Fig. 25 & 26**
2. Reinstall fabric. Repeat for opposite side.



Fig. 25

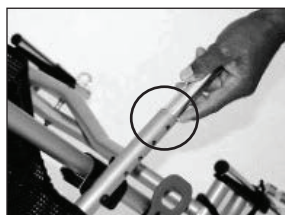

Fig. 26

Attaching Support Strap for Seat Extension Tubes

1. Remove seat upholstery. **Fig. 27 & 28**
2. Change and install seat depth tubes. Press spring button and move seat depth tube to desired setting. **Fig. 29**
3. Install support strap. **NOTE:** Make sure rough, shiny side of strap is facing out. **Fig. 30-33**
4. Install Seat Upholstery. **Fig.34**



Fig. 27



Fig. 28



Fig. 29



Fig. 30



Fig. 31



Fig. 32



Fig. 33



Fig. 34

FOR TEXTILENE UPHOLSTERY: (only applicable to EZ 14-18) Make sure the seat depth tube inserts into the black web loop located on the inside corner of the textile upholstery. **Fig. 35-37**



Fig. 35



Fig. 36



Fig. 37

NOTE:

Do not use black web loop on the shortest adjustment of the small seat depth tubes.

Two-Piece Seat

The lower seat panel is attached to the back panel with hook and loop straps. It is used to take up slack in the seat panel after seat depth adjustments have been made. **Fig. 38, 39 & 40**



Fig. 38

Excessive hook and loop overlap lifts seat fabric and pushes hips forward, creating poor posture and reducing effective seat depth.

Fig. 39



Correct hook and loop strap adjustment provides room for hips, and makes greater use of seat depth.

Fig. 40



Wheels

Wheel Options

The EZRider comes standard with solid front and rear tires. You can upgrade, replace or reorder tires at any time. You have the option of upgrading to pneumatic tires or re-ordering replacement standard solid tires. When ordering upgraded or replacement tires, please have the following information available:

Chair model and size (ex: EZ12)

Wheel size (ex: 7.5" x 2"/190mm x 51mm)

EZ-12/14/16 (Fig 41)

Pneumatic Tire Sizes (option)

7.5" x 2"/190 x 51 mm (front)

11.5" x 2.5"/290 x 60 mm (rear)

EZ-18 (Fig 42)

Pneumatic Tire Sizes (option)

8" x 2" /203mm x 51mm (front)

12.5" x 2" /318mm x 51mm (rear)



Fig. 41



Fig. 42



CAUTION: Do not use the chair unless it has proper tire pressure. (Front 36 psi/Rear 30 psi, 248kPa/200kPa, 2.5BAR/2.0BAR) Do not overinflate the tires. Failure to follow these instructions may cause the tire to explode and cause harm.

Quick Release Wheels

Tire Removal:

1. To remove, press down and hold the Rear Wheel Locking Pin. Grasp wheel and pull.
Fig. 43 & 44
2. No tools are required to remove tire. **Fig. 45**



Fig. 43

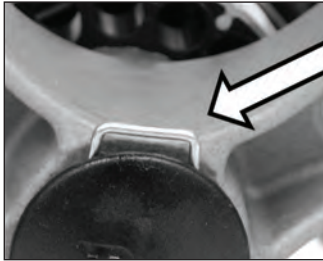

Fig. 44 Rear Wheel Locking Pin



Fig. 45



CAUTION: Ensure the wheels are installed properly. You will hear a “click” when wheel locks into place.

Tire Installation:

1. To install, slide wheel onto rear axle and push with ball of hand until it clicks into place.
Fig. 46 & 417



Fig. 46



Fig. 47

Anti-Shimmy Adjustment

If the front wheels develop a shimmy, use a wrench to tighten the stem nut. Adjust the stem nut clockwise until the shimmy disappears. **Fig. 48**



Fig. 48

Locking and Unlocking

Convaid manufactures two types of wheel locks: hand operated and foot operated. Check to see which type of wheel locks is on your chair.



CAUTION: Proper care and maintenance must be taken to ensure proper function of the foot operated brakes.



CAUTION: When operating the wheel lock, do not use excessive force to engage the locks with your foot. Only light pressure is needed to fully engage the locks.



CAUTION: Teflon spray should be applied to brake components weekly to ensure proper operations.



CAUTION: Excessive force or poor maintenance will cause premature failure for foot operated brakes.

Foot Operated Wheel Locks

To Release Lock:

Lift upward on wheel lock. **Fig. 49**



Fig. 49

To Lock:

Press downward on wheel lock **Fig. 50**



Fig. 50

Toggle Wheel Locks

To Release Lock:

Pull up on red handle. **Fig.51**



Fig. 51

To Lock:

Pull down on red handle. **Fig. 52**



Fig. 52



Fig. 53



CAUTION: Be careful not to get your fingers caught **Fig. 53**

Operating Instructions

Three-Point Pelvic Belt

Adjust the belt so the user stays securely in position. The quick release buckle is attached to the crotch strap, and joins the crotch strap to both belts.

To Buckle:

Slip the metal clasps on the belt strap into the sides of the buckle. **Fig. 54**

To Release:

Press the grey button on the buckle and pull out the clasps. **Fig. 54**



Fig. 54



CAUTION: Always secure user with belt first, before making any other adjustments.

The three-point pelvic belt can be adjusted by threading the strap through the desired slot. **Fig. 55**



Fig. 55

H-Harness with Padded Covers

H-harness shoulder straps help the user retain upright trunk position. To adjust, insert the bolt at the end of the strap through the grommet hole in the seat back. Grommet choice should be level with or higher than the top of the shoulders. Choose a hole that will keep the user secure without the strap rubbing against the face or neck. Secure the strap with the threaded knob. **Fig. 56- 58**

Shoulder pads for the H-harness are standard. The pads come equipped with a snap buckle for easy attachment. **Fig. 56**



WARNING: Keep fingers away from the adjustment holes.



Fig. 56



Fig. 57



Fig. 58

Footplate Height Adjustment

Seat-to-footplate height is measured from the back of the knee to the bottom of the heel. Feet or heels should rest comfortably on top of footplate. **Fig. 59**

- All Convaid footplates are height adjustable.
- Footplates swing away for access or folding.

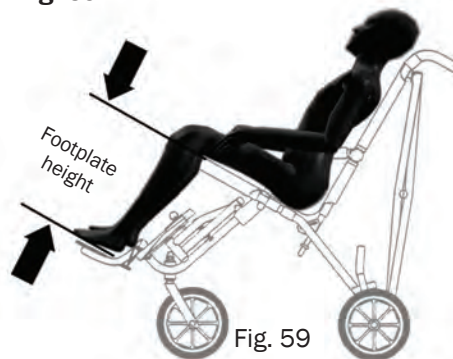

Fig. 59



Fig. 60

Pull on ring to remove detent pin holding footplate in place. Move footplate up or down, realign holes and replace pin through holes in tube.

Fig. 60

Additional Footplate Height Adjustment:

In the event that the footplate height adjustment described above is inadequate, additional adjustments can be made.

1. Pull out detent pin and remove the footplate extension tube from the frame. **Fig. 61**
2. Press the spring button, then pull the footplate assembly apart. **Fig. 62**
3. Insert the footplate into the opposite end of the footplate extension and reassemble. **Fig. 63**



Fig. 61



Fig. 62



Fig. 63

For Additional Range:

1. Using a 5/32" Allen wrench (included), remove both bolts from the housing bracket on the mobility base. Flip the bracket upside down and replace bolts. **Fig.64 & 65**
2. Return the footplate extension tube to the housing bracket and secure with detent pin. **Fig. 66**



Fig. 64



Fig. 65



Fig. 66



CAUTION: Keep fingers away from adjustment holes

Angle Adjustable Footplates

Angle adjustable footplates can be moved before and after, sideways, and rotated vertically and horizontally. To adjust the angle, loosen the bolts on the footplate and move to desired position. Re-tighten the bolts. **Fig. 67-71**



Fig. 67



Fig. 68



Fig. 69



CAUTION: Keep fingers away from slots.



Fig. 70



Fig. 71

Footplate Depth Adjustment

All EZRider chairs offer adjustable footplate depth. Use the 5/32" Allen wrench to loosen the two bolts located on the top of the footplate. Slide footplate forward or rearward to desired depth. Re-tighten bolts. **Fig. 72**



Fig. 72

Caster Locks

Caster locks hold the swivel wheels in a forward facing position to prevent the wheels from turning side to side. (For 5mm wide tires only) **Fig. 73**



Fig. 73

Calf Panel

1. Lay Calf Panel flat and unfasten the hook and loop straps. **Fig. 74**
2. Attach hook and loop straps around Footrest Extension Tube.
3. Position Calf Panel across chair and attach hook and loop straps around opposite Footrest Extension Tube. **Figs. 75 & 76**



Fig. 74



Fig. 75



Fig. 76

Accessories

Convaid offers a wide variety of accessories to help properly position the user.

NOTE: Convaid's chairs provide a semi-contour fit around the body. The user must be fitted correctly into the chair to achieve optimal posture and comfort.

Full Torso Swing-Away Support Vest

An adjustable support vest keeps the user in place comfortably and securely. It helps to maintain midline seating position and prevents forward slumping. The vest is attached to the chair with straps that wrap around the seat back and connect with hook and loop straps, and shoulder straps that screw into the seat back. Adjust the side straps for proper fit. **Fig. 77**



Fig. 77

Lateral Thigh Support (Adductor)

Pulls thighs together, improving hip alignment and stabilizing seating position. The degree of adduction can be varied and can favor one side. Fold the adductor flaps over the thighs, wrap the straps under and around the armrest tube and attach with buckle.

Fig. 78

The adductor is attached with screws at the end of the seat tubes.



Fig. 78

Medial Thigh Support (Abductor)

Separates the thighs to improve hip alignment and stabilize sitting posture. Degree of abduction can be varied and can favor one side. The abductor flaps wrap over the user's thighs from the inside to the outside. The straps buckle around the seat tube or the armrest. They can also be wrapped around the armrest tube twice for high tone children. **Fig. 79**

The abductor is attached with screws at the end of the seat tubes.



Fig. 79

Padded Headwings

Adjustable padded headwings provide soft foam support for midline positioning. **Fig. 80.** The padded headwings can be attached at any height by wrapping the hook and loop straps around the frame and attaching at the back of the chair. Secure headwings by tying laces through the grommet holes in the back of the seat fabric or headrest extension. **Fig. 81**



Fig. 80



Fig. 81

Headrest Extension

The headrest extension fits easily into the sockets on the seat back. Fold chair slightly. Move rubber grommets on the mounting posts to adjust the height of the seat back extension. **Fig. 82 & 83**



CAUTION: To reduce the possibility of injury, the headrest extension must be used with transit models.



Fig. 82



Fig. 83

Height Adjustable Flip-Up Armrests

The height adjustable flip up armrests provide added support and positioning. The armrests flip up out of the way for easy access into the chair, and adjust in height for added comfort. **Fig. 84**

To attach or adjust the height of the armrests, remove the two screws from each bracket with a 5/32" Allen wrench, adjust the bracket to the desired height, and reinsert the screws. **Fig. 85**



Fig. 84

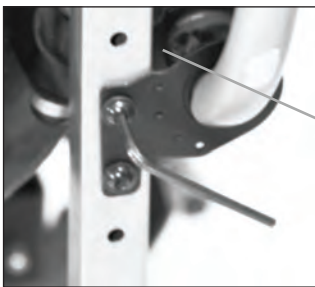

Fig. 85



CAUTION: Do not use armrest to lift the chair.

Occi Headwing

Occi Headwing supports and positions the head at the occipital area. This headrest provides added comfort, allows side to side head movement without obstruction, and does not block the individual's ears and line of vision. **Fig. 86**

The Occi headwing can be attached at any height. Secure headwing by tying laces through the grommet holes at the back of the seat fabric or headrest extension.



Fig. 86

5-Point Harness

Adjusting The Straps

1. Release the Rear Lock Brace by lifting up on the center of the brace. **Fig. 87**
2. Press in the silver snap button on the Rear Lock Brace. **Fig. 88 & 89**
3. Pull the lock brace off of the housing. **Fig. 90**
4. Pull shoulder strap through the upholstery, reposition to the desired height, and reinsert it back through the seat upholstery. **Fig. 91**
5. Slide the shoulder harness loop on to the Rear Lock Brace. **Fig. 92**
6. Release the Rear Lock Brace by lifting up on the center of the brace. **Fig. 87**
7. Reinsert the Lock Brace onto the housing by pushing it with the palm of your hand. **Fig. 93 & 94**
8. Lock the Rear Lock Brace by pressing down on the Rear Lock Brace. **Fig. 95**

NOTE: The shoulder straps should be positioned in slots that are slightly above the shoulders of the child, and as the child grows, they should be moved to maintain a height above the shoulder level.

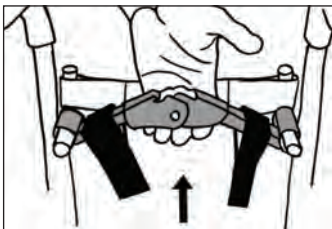

Fig. 87



Fig. 88

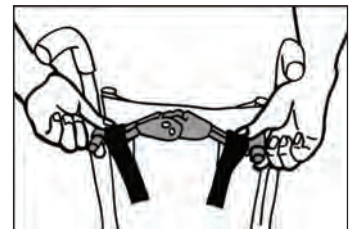

Fig. 89



Fig. 90



Fig. 91

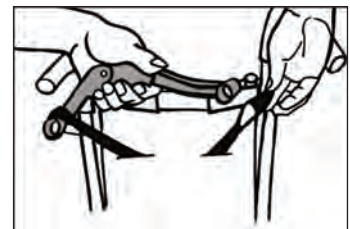

Fig. 92



Fig. 93



Fig. 94

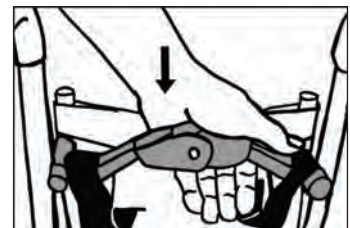

Fig. 95

Adjusting The Pelvic Belt Strap

To Tighten:

Tighten the pelvic belt straps by pulling on the loop located at the end of the strap.

Fig. 96

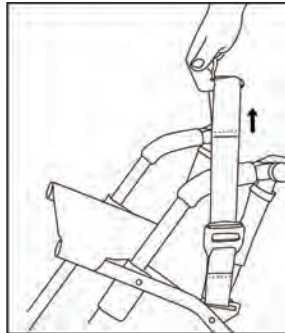

Fig. 96

To Loosen:

Loosen the pelvic belt strap by pushing the gray button on the Strap Adjustment Lock B and pulling on the end of the strap closest to the buckle. **Fig. 97**

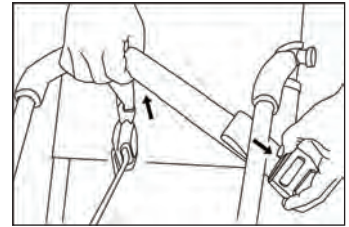

Fig. 97

Adjusting The Crotch Strap

To Tighten:

Tighten the Crotch Strap by pulling on the loop located at the end of the strap.

Fig. 98

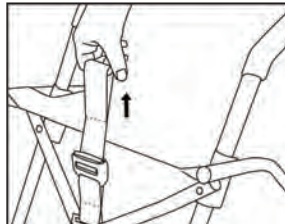

Fig. 98

To Loosen:

Loosen the Crotch Strap by pushing the gray button on the Strap Adjustment Lock and pulling. **Fig. 99**

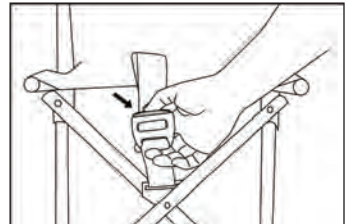

Fig. 99

Seat Cushions

Support: General Use Cushion

Flat foam with wooden insert **Fig. 100**

- Promotes stability and posture control and provides comfort for the user.
- Waterfall front eliminates pressure points at the back of the knees.



Fig. 100

Position: Medial Thigh Support and Anti-Thrust Cushion

Contoured foam with wooden insert **Fig. 101**

- Medial thigh support helps position the legs out of adduction and into better alignment, which can provide for improved weight-bearing balance and stability.
- When used with a lap belt, the 25 mm anti-thrust shelf in front of the ischials (seat bones) helps eliminate sliding or thrusting forward of the pelvis. This provides improved stability and reduces sacral sitting.



Fig. 101

Align: Lateral Pelvis and Lateral Thigh Support Cushion

Contoured foam with wooden insert **Fig. 102**

- Contoured edges provide lateral, pelvic and thigh positioning to reduce lateral movement of the pelvis and improve lower extremity stability.
- Increased surface contact for better weight distribution.



Fig. 102

Fitting

The fitting of the cushion should be done by a clinician. When fitted correctly, the cushion will help provide stable support and promote good posture. Consult your clinician for questions regarding individual needs.

Select the cushion size to match the seat width and depth of the chair. Measure the distance between the back of the buttocks and the back of the knees. Subtract 25mm - 51mm to allow for adequate clearance between the seat and the back of the knees.

1. Apply wheel locks. Never leave occupied chair unattended.
2. With the material identification tag towards the rear of the chair, place the cushion onto the seat upholstery. Line up the hook and loop straps to secure the cushion in place. Front end of cushion should line up with the front edge of the seat upholstery. Position the hips of the occupant to the back of the seat. The ischials (seat bones) should be centered on the seat well of the cushion. Use positioning belt to buckle occupant into the chair.
3. Adjust the wheelchair footrest height so that the user's leg rest firmly but comfortably on the cushion. Proper footrest adjustment will enhance sitting comfort and help lower peak sitting pressures. If applicable, readjust armrest height and lateral trunk supports.

Caution

The height and weight of the occupant, in conjunction with a seat cushion, may affect the center of gravity and cause the wheelchair to become unstable, potentially resulting in injury. Prior to use, assess the stability of the wheelchair by sitting in it with the cushion attached. Do not exceed wheelchair weight limit.

Ensure the cushion's hook and loop straps are in good condition and is aligned properly with the hook and loop straps on the wheelchair seat. Make sure the cushion is firmly attached. An improperly attached cushion may cause sliding, potentially resulting in injury.

Changes in the user's condition or growth, weight or changes in wheelchair equipment or accessories may require reassessment by a clinician to ensure proper cushion fit and suitability. Skin should be constantly checked by the user's caregiver for any signs of reddened areas or skin sensitivity. These areas should be brought to the attention of your clinician. The clinician should also assist you with assessing the cushion for any possible areas that have bottomed out.

Headrest Cover (Canopy)



Fig. 103

Attaching Canopy

1. Remove Canopy from box. **Fig. 103**
2. Align plastic Canopy Retaining Clips with upper tubing on back of the chair. **Fig. 104**
3. Push on clips with the ball of your hand until they snap into place. **Fig. 105**



CAUTION: Keep fingers away from moving parts.



Fig. 104



CAUTION: To prevent breakage of canopy clips, always carefully follow the instructions and avoid twisting when attaching or removing the canopy

4. To open, grasp top of Canopy, push forward and rotate downward. **Fig. 106-108**
5. To close the rear flap of Canopy, attach the hook and loop strap to the hook and loop receiving patch on the edge of the Canopy Hood. **Fig. 109** To fold, repeat above steps in reverse order. **Fig. 110**



Fig. 105



Fig. 106



Fig. 107



Fig. 108



Fig. 109



Fig. 110

Heavy Duty Reinforced Upholstery



Heavy duty, reinforced, padded seat and seat back come with pockets which have removable plastic stiffeners. Use when extra firmness is required. Stiffeners easily lift out of pockets for custom forming with a heat gun. **Fig. 111**

Fig. 111

Reducer Seat Insert



The Reducer Seat Insert provides proper positioning in an oversized wheelchair. This cushion easily slips into the seat of the chair to reduce the seat width 51 mm and the seat depth 25 mm. The ribbed surface provides comfort and promotes airflow. **Fig. 112**

Fig. 112

Rear Anti-Tip Tubes

1. To install the anti-tip tube, align the tube with the end of the square frame tubing located next to the rear wheel. **Fig. 113**
2. Position the anti-tip tube onto the square frame tubing **Fig. 114**, and push until the “release button” pops through the hole located on the anti-tip tube. **Fig. 115**
3. Repeat steps 1 & 2 for opposite side.
4. To remove the anti-tip tubes, perform above steps in reverse order.



Fig. 113



Fig. 114



Fig. 115



CAUTION:

The use of anti-tip tubes should be If the user's weight is less than 50lbs (22.7kg)

See diagram below for how to configure anti-tip tube for your specific size. **Fig. 116 & Fig. 117**

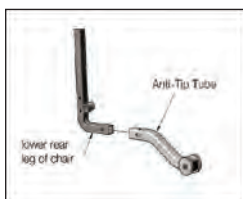

Fig. 128 (For EZ 12 & 14)

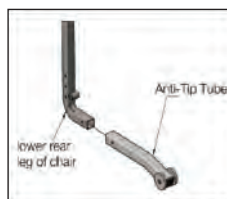

Fig. 129 (For EZ 16 & 18)

Utility Bag

The Utility Bag attaches to the back of the chair, but can be removed and converted to a tote bag.

Fig. 118 & 119

To attach:

1. Hook clasps onto straps. **Fig. 118**



Fig. 118



Fig. 119

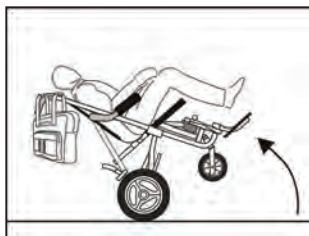

Fig. 120



CAUTION: Do not overload bag. **Fig. 120**

Transit Models

Transit Option



The wheelchair transport model has been crash tested and performed satisfactorily at 30 mph/20g deceleration. The optional models conform to RESNA WC-19 and ISO 7176-19 standards. Dummy weights are:

All EZRiders

Model EZ12T.....66lbs / 30kg

Model EZ14T.....100lbs / 45.5kg

Model EZ16T.....170lbs / 77kg

Model EZ18T.....170lbs / 77kg



CAUTION: Convaid belts and shoulder straps are for positioning only and are not to be used as a vehicle restraint.

Fig. 121

To reduce possibility of injury, the headrest extension must always be used with the chair.

The following instructions should be followed to minimize impact in case of a crash:

1. During transit, the chair must be forward facing with tray and storage basket removed.
2. Use only a tested, proven and compatible 4-point wheelchair tie-down system (WTORS), and a 2 or 3-point occupant restraint system in accordance with WC4-18 or ISO 10542-1.
3. The wheelchair tie-downs must be securely attached to the four black anchor points on the chair. See arrows in above photo for anchor points.
4. The occupant restraints must include a lap and a shoulder bet, secured directly to the EZRider frame and side of roof of vehicle.
5. All floor tie-down straps must be drawn tight in the front and the back to eliminate any forward/aft movement of the chair.
6. Wheelchair restraint manufacturers' instructions must be followed precisely to ensure intended performance.

NOTE: Tray, storage basket and other accessories must be removed during transport in bus or van, except when medically necessary.

NOTE: Do not overtighten. This may cause damage to the frame.

Wheelchair Lateral Stability and Belt Restraint Accommodation Rating

Wheelchair Model	Mass (Weight) of Wheelchair (lb./kg)	Test Rating	Lateral Stability* (in./mm)
EZ12T	25/11.4	Acceptable	0.79/20.1
EZ14T	30/13.6	Acceptable	1.18/30.0
EZ16T	30/13.6	Acceptable	1.18/30.0
EZ18T	29/13.2	Acceptable	1.57/39.8

* “Lateral stability” is the displacement of point P (the center of gravity on the loaded wheelchair) when a platform with the loaded wheelchair is tilted 45° laterally from the horizontal. Higher numbers indicate less stability.

This table refers to tests performed in accordance with WC-19 to establish lateral stability during normal travel and the ease of use and proper fit of vehicle-anchored belt restraints. The letter designation reflects the overall rating of the lap and shoulder belt position.

Transit Mode Instructions

Using the EZRider Chair for Transportation in Motor Vehicles

The OPTIONAL Transit Version EZRider can transport users in motor vehicles that are compatible with Occupant Restraint Systems (WTORS). The chair MUST be secured in a forward-facing position with a Wheelchair Tie-down and Occupant Restraint System (WTORS), which meets the requirements of WC-4 and ISO 7176.



CAUTION: The wheelchair should be used as indicated in the User’s Guide instructions accompanying the wheelchair. Failure to do so increases the likelihood of serious injury in a vehicle crash.



CAUTION: Do not attach tiedowns anywhere except designated tiedown locations.



CAUTION: During transit, chair must be forward facing with all accessories removed.



CAUTION: Do not alter or substitute any part or component of the wheelchair, wheelchair frame or wheelchair seating system.



CAUTION: EZRider was dynamically crash tested in a forward- facing configuration using an appropriately sized crash-test dummy restrained by both upper-torso (shoulder) and lower-torso (lap) belts. To reduce the possibility of head and chest injuries resulting from contact with vehicle components, you must use both upper and lower torso belts.



CAUTION: Both pelvic and torso restraint belts must be used while traveling aboard a motor vehicle.



CAUTION: When riding aboard a motor vehicle, it is preferred that the wheelchair user transfer into the vehicle's manufacturer's seat and use a federally approved, crash-tested seat.



CAUTION: Whenever possible, auxiliary wheelchair equipment should be removed from the wheelchair and secured in the vehicle during transit so that it does not break free and cause injury to vehicle occupants during a crash.



CAUTION: Do not use the chair if it has been involved in a crash.



CAUTION: Adequate clear zones are required for occupants restrained by both upper and lower-torso belt restraints. See **Figs. 122 & 123**.

Recommended Clear Zones in Vehicle

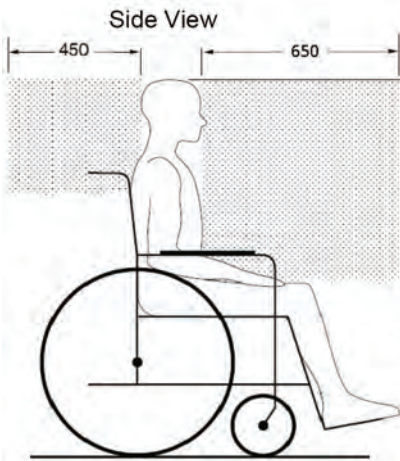

Fig. 122

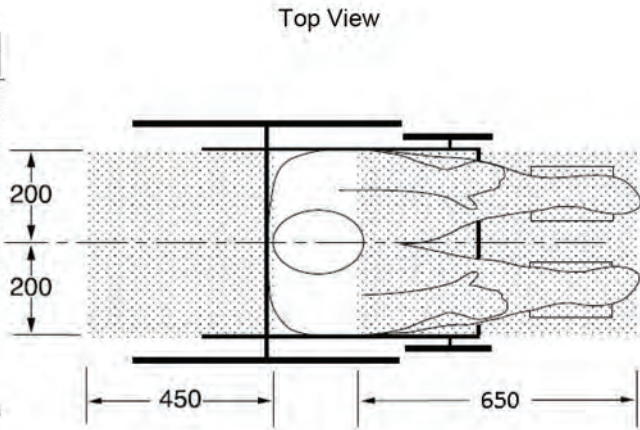

Fig. 123

The rear clear zone is measured from the rearmost point on an occupant's head. The front clear zone is measured from the front-most point on an occupant's head.

Dimensions are shown in millimeters.

Providing Clear Space & Padding

Position the wheelchair aboard the motor vehicle to ensure sufficient clear space in front of, and behind, the occupant. See **Figs. 122 & 123**



CAUTION: If there are any hard or sharp objects or components near the wheelchair, such as components of lifts or fold-up seats, they must be covered with heavy-duty energy-absorbing padding to ensure the safety of the wheelchair occupant and other passengers.

Proper Use of Equipment

Securing the Wheelchair

Attach tiedown straps to securement points (black brackets) located on the wheelchair's legs in accordance with the WTORS manufacturer's instructions. Securement points are identified by the symbol in **Fig. 124** and their location on the wheelchair illustrated in **Fig. 125**.

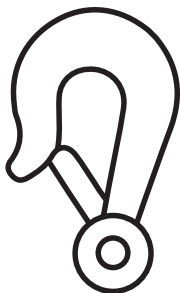

Fig. 124



Fig. 125

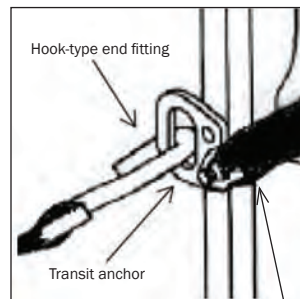

Fig. 126

Lap belt anchorage

When securing the occupied wheelchair, it is important that the WTORS anchor points on the floor and wall of the motor vehicle are positioned properly according to the WTORS manufacturer's instructions. The wheelchair must be positioned facing forward inside the vehicle. Position the wheelchair between the front and rear tiedown anchor points, allowing for the correct angle of adjustment of the tiedown straps, as illustrated in **Fig. 126**.

Your Convaid transit wheelchair can be easily secured by four-point strap-type tiedowns by attaching the hook end fittings of the tiedown straps to the four black securement-point brackets located on the four tubular legs of the wheelchair or by threading tiedown straps through the openings in the securement points.

The floor anchor points and wheelchair should be located:

- so that the tiedown straps follow a straight, clear path from the wheelchair securement points to the floor anchor points and
- so that the front straps are angled outward from the sides of the wheelchair and
- so that the rear straps are anchored straight back from the wheelchair securement points

Once all four tiedown straps are attached to the wheelchair:

- inspect all tiedown straps for signs of wear to the webbing and replace any straps that are worn and
- tighten the straps to remove any excess slack and provide tension between the front and rear tiedown strap securement points.

PREFERRED ANGLES OF FRONT AND REAR TIEDOWN STRAPS **Fig. 128** AND PREFERRED LOCATIONS OF FLOOR ANCHOR POINTS. **Fig. 127**.

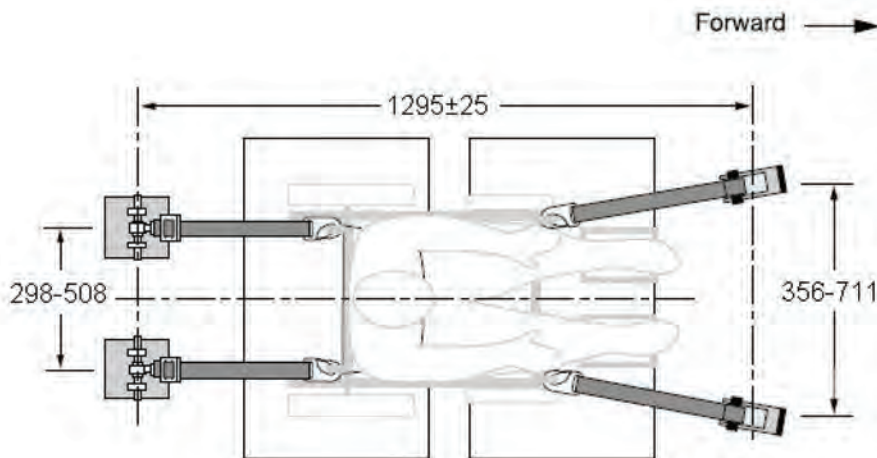

Fig. 127

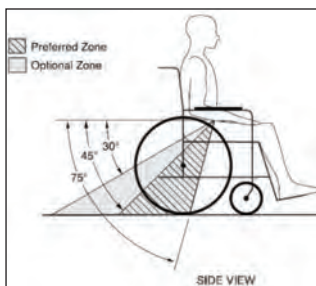

Fig. 128

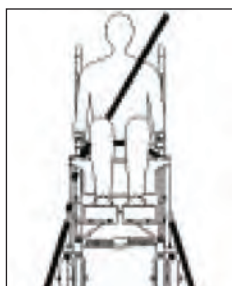

Fig. 129



Fig. 130

FIG. 129: FRONT TIEDOWN STRAPS ANGLED AWAY FROM SIDES OF WHEELCHAIR.

FIG. 130: CORRECT POSITIONS OF SHOULDER AND LAP BELT RESTRAINTS AND WHEELCHAIR TIEDOWNS.

STANDARD METAL CLIP **FIG. 131** AT LOWER END OF SHOULDER BELT AND AT END OF OPTIONAL WHEELCHAIR-ANCHORED LAP BELT USED TO CONNECT TO PIN/BUSHING **FIG. 131** ON LAP BELT OR ON WHEELCHAIR SECUREMENT POINT BRACKETS.

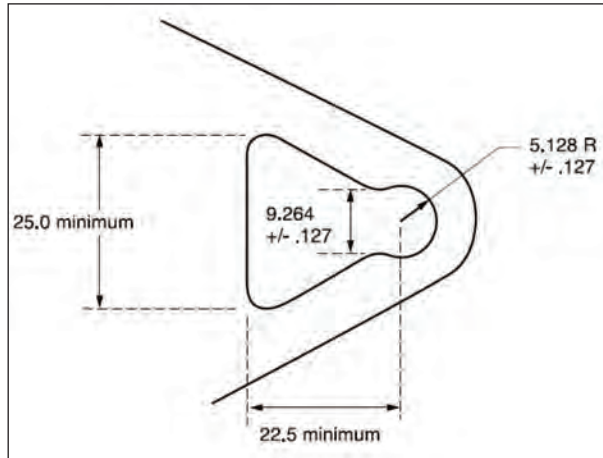

Fig. 131

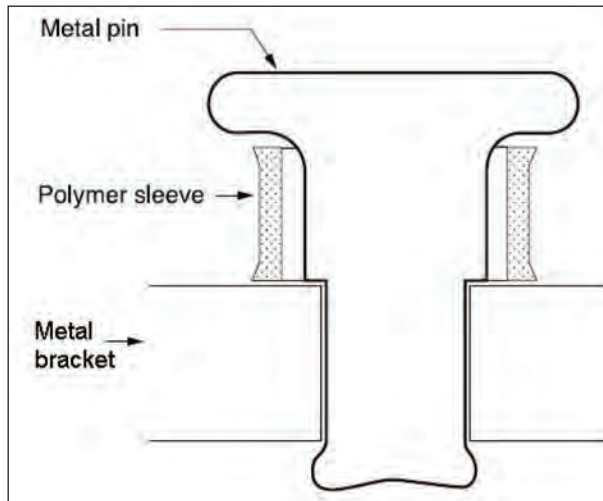

Fig. 132

Restraining the Wheelchair Occupant

Your Convoid transit wheelchair was dynamically crash tested in a forward-facing configuration using an appropriately sized crash-test dummy restrained by both upper-torso (shoulder) and lower-torso (lap) belts. To reduce the possibility of head and chest injuries resulting from contact with vehicle components, you must use both upper and lower torso belts. (See **Figs. 129 & 130**)

Your Convoid transit wheelchair provides for the use of an optional wheelchair-anchored lap belt. The optional belt, which has been dynamically tested in accordance with Annex A of WC19, may be ordered from Convoid at a nominal additional cost. To attach the lap belt to the wheelchair, secure the metal clips at the ends of the lap belt (**Fig. 131**) to the pin/bushing connectors located on the wheelchair's rear securement-point brackets. (**Fig. 132**)

Before loading the wheelchair onto the vehicle lift, fasten the lap belt over the wheelchair user's pelvis. The wheelchair user should wear the optional lap belt as low over the pelvis and as snugly as possible without compromising comfort. The vehicle-anchored shoulder belt may then be clipped to the pin/bushing connector located on the lap belt near where it attaches to the chair. When not in use, the optional lap belt may be looped underneath the seat, buckled, and tightened.

If the wheelchair is purchased without the optional lap belt or if the wheelchair user elects not to use the belt, a vehicle-anchored lap and shoulder belt must be used. As with the wheelchair-anchored lap belt, it is very important to position the vehicle-anchored lap belt low over the pelvis so that the angle of the lap belt is within the preferred zone of 45° to 75° to the horizontal or the optional zone of 30° to 45° to the horizontal, as shown in **Fig. 127**

NOTE: Steeper side view pelvic-belt angles are especially important if the pelvic belt is intended to be used for postural support in addition to occupant restraint in a frontal crash. Steeper angles will reduce the tendency for a vertical gap to develop between the user and the belt due to compliance of seat cushions and belt movement, thereby reducing the tendency for the user to slip under the belt or for the belt to ride up on the soft abdomen during normal use.

NOTE: Steeper belt angles also reduce the tendency for upper-torso belts to pull the pelvic belt onto the abdomen during frontal impact loading.

Be sure that the shoulder belt crosses the chest and the middle of one shoulder and that belt restraints are not held away from the body by wheelchair components or parts, such as arm rests or wheelchair legs. (See **Fig. 133**)

Thread the lap belt under the frame tubes located directly under the user's elbows and pull the belt snug against the pelvis. Ensure that belt webbing is not twisted as this may compromise safety. It is best for EZRider to be transported with the seat in a relatively upright orientation. However, if the seat must remain in a tilted position for medical reasons, the seat back should not be reclined more than 30 ° from the vertical. If it is necessary to recline the seat more than 30 °, move the shoulder belt anchor point rearward on the vehicle wall so that the shoulder belt remains in contact with the wheelchair user's shoulder and chest.



Fig. 133

Using Postural Belts & Supports

Positioning accessories such as pelvic positioning belts, anterior trunk supports, and lateral trunk supports may be used while in transit, but are not designed to provide restraint during a crash.

Postural supports and belts should therefore not be relied on for restraint in a vehicle crash and should be used only in conjunction with lap and shoulder belts that have been designed for restraint in a motor vehicle and crash tested in accordance with SAE J2249/ WC-4, ANSI/RESNA WC19 and/or ISO 10542-1.

Trays & Other Wheelchair Components

To reduce the risk of potential injury to the wheelchair user or other occupants in a motor vehicle crash, wheelchair-mounted accessories, such as trays and respiratory equipment, must be removed and secured separately during transit. Use tether straps or other strong attachment hardware to prevent items from breaking loose and causing injury during a crash.

WTORS Manufacturers

Convaid is a wheelchair manufacturer and does not offer wheelchair tiedown and occupant restraint systems (WTORS). However, products that comply with current WTORS standards can be obtained from the following companies that specialize in crash-tested WTORS:

Q'Straint, Unwin and Ortho Safe specialize in crash-tested tie-down systems and are in no way associated with Convaid.

Ortho Safe Systems

P.O. Box 9435
Trenton, NJ 08650 U.S.A
(609) 587-9444

Unwin Safety Systems

Unwin House
The Horseshoe Coat Road,
Martock, TA12, 6EY U.K.
(44) (01935) 827740

Q'Straint

United States & Latin America
4031 NE 12th Terrace Oakland Park,
FL 33334 U.S.A
(954) 986-6665

Miscellaneous

Fabric Removal

Partially fold the chair to relieve fabric tension (see fold instructions on page 10). The lower seat panel is attached to the back panel with hook and loop straps. Remove the seat bottom. Press grey detent pin at the end of the seat extension, and take off upholstery. **Fig. 134 & 135**

To remove the top portion of the seat, remove the hook and loop straps that attach the seat upholstery to the frame, and take off upholstery. Lift fabric off seat tubes and away from upper handles. The seat reinforcing strap should remain on frame. **Fig. 135 & 136**



Fig. 134



Fig. 135



Fig. 136

Adjustable Tension Back

1. To adjust the Tension Back, unfasten the hook and loop straps and pull to desired firmness. **Fig. 137**
2. After adjustments are made, refasten hook and loop straps. Repeat steps 1 and 2 on each set of straps. **Fig. 138 & 139**



Fig. 137



Fig. 138



Fig. 139

Important Information

Maintenance, Operating & Safety Instructions

- READ ALL INSTRUCTIONS BEFORE USING THE PRODUCT
- ALWAYS FOLLOW THESE SAFETY INSTRUCTIONS
- SAVE SAFETY INSTRUCTIONS FOR FUTURE REFERENCE



CAUTION :

- For increased safety, the seat belt should be used at all times.
- Do not leave user unattended.
- Do not strap user too tight.
- Straps should not interfere with breathing or circulation.
- Always apply wheel locks before letting go of the chair.
- If front edge of seat is at or forward of the point where tires touch the floor, avoid using front of seat tubes for support during entry or exit from chair to prevent tipping.
- Avoid using footplates for weight support during exit or entry of the chair.

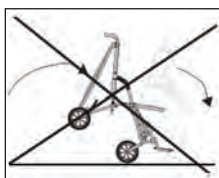

Fig. 140

Waste Disposal

The shipping carton should be kept for possible return to the manufacturer/service facility for repair or maintenance. Other paper packaging waste should be set aside for recycling. For disposition of replaced parts or the complete chair, the materials should be separated into: plastic, rubber, steel, aluminum, etc., and set aside for recycling.

Chair Maintenance

The following maintenance procedures should be conducted on a regular basis: Examine your Convaid product visually from time to time for possible wear and tear. Lubricant should be applied to frame and moving parts to maintain easy folding and adjustment.

- Tire Air Pressure:** The air pressure in your tires should be checked WEEKLY, since low air pressure may affect brake ability.
- Axles and Moving Parts:** Axles and moving parts should be wiped off WEEKLY with a slightly moist cloth, to remove dust, dirt and mud. Apply some lubricant after each cleaning.
- Repair or replace loose, worn, bent, missing or damaged parts before using the chair!**
- Flat Tire:** In the event of a flat tire, please contact customer service or your local dealer for specific repairing instructions.

IMPORTANT INFORMATION

Check for functionality and/or damage of the following:	Weekly	Every 3 months	Every 6 months	As necessary
Rims and tires	•			
Wheel lock and hand brakes	•			
Accessories	•			
Front and rear wheel axles	•			
Cleaning & lubricating all moving parts*	•			
Belts, zippers and hook and loop straps closures		•		
Seat/back upholstery**/tautness		•		
Armrests & foam (cushioned parts)			•	
Frame			•	
Contacting a Convaid Dealer for service or repair***				•

* Use a non-toxic, hypoallergenic dry lubricant for all moving parts of the frame.

** Follow cleaning instructions for appropriate user hygiene.

*** Repair or replacement of non-removable, worn or broken parts must be performed by a qualified service facility.

Cleaning and disinfection

To prevent the spread of germs, clean all skin contacting areas with disinfectant wipes regularly. Keep frame dry and apply a non-toxic, hypoallergenic and biodegradable lubricant to all moving parts. After longer storage periods, and before further use, the entire chair needs to be serviced, cleaned, and disinfected.

Cleaning of frame

Frame is to be kept dry and free of dirt and should be wiped off with a non-toxic, hypoallergenic and biodegradable wipe. Lubricant should be applied to moving parts as needed to maintain easy folding and adjustment.

Corrosive substance such as salt water should be avoided at all times. If exposed the frame should be wiped off with a moist towel as soon as possible. Water and a soft cloth are sufficient for basic cleaning.

Cleaning of wheels and brakes

Wheels and locks should be kept free of dirt or mud after each use. Foreign objects could cause interference with moving parts. Wipe wheels and locks with a moist cloth as needed.

IMPORTANT INFORMATION

Cleaning of fabric cover

Seat and back upholstery can be easily removed, washed, air dried and reattached to the chair. Use standard detergent to wash fabric.

Cushioned parts can also be removed from chair, washed or wiped off with a moist cloth. Before reattaching them to the chair, make sure they are completely dry. Use standard detergent to wash fabric. Use gentle cycle and cold water. Hang Dry.

Parts that are permanently attached may be wiped thoroughly with a moist cloth. Allow sufficient time to dry before placing user in chair.



Storage

Store your chair in a clean, dry area and avoid extended exposure to heat or moisture. After extended storage periods, and before reuse, the entire chair needs to be serviced, cleaned and disinfected.

Reuse

Your Convaid chair should undergo wipe-down disinfection before reuse.

Please use a non-toxic, biodegradable disinfectant solution suitable for surface disinfection. Please check the following components for intactness before operation. (see MAINTENANCE CHART)

Repair or replace if necessary:

- Wheels (tread pattern), air pressure if applicable
- Frame
- Seat and back upholstery
- Wheel lock operation
- Bearings and axles: check wear and tear/ lubrication
- Straight-running stability of wheels
- Attachments

Repairs

User: The user can replace easily removable parts or accessories, e.g. foot supports, heel loops, all fabric items, hand grips, etc.

Manufacturer/Service Facility: Repair or replacement of permanently attached, worn or broken parts must be performed by a qualified service facility. Any individual part of the chair can be replaced. Contact the manufacturer/service facility for needed repairs. The chair should be packaged in the original or suitable shipping carton for return to the manufacturer/service facility. Ship via UPS.

IMPORTANT INFORMATION

Tools Required

- Tools needed include 3/8", 7/16", 3/8" or 2 adjustable wrenches with 3/4" capacity, Phillips head screwdriver 5/32"
- Allen wrench (included)

Spare Parts

If you need any spare parts for your chair, please visit or call the Convaid service dealer you purchased this chair from. If the part is not under warranty, you will receive an estimate of the cost and, if necessary, shipping instructions for the return of the chair for repairs.

Functional Tests

All four wheels should make contact with the floor. With the chair empty, push it forward on a smooth level surface with enough momentum to travel six feet (2 m). The chair should not veer to the left or right more than six inches (150 mm). Wheels should be free running. Following the fold/unfold instructions; the chair should fold/unfold smoothly without undue effort. All fasteners should be secure. Fasteners on moving joints should not be overtight. Seat fabric should not be wide-stretched or sagging. Positioning accessories should be correctly adjusted and secure.

EC REP

EU Authorized Representative

R82 A/S
Parallelvej 3,
8751 Gedved, Denmark



Convaid Service Dealer

Please record the Convaid Dealer from which you purchased your chair:

Company: _____

Address: _____

Phone: _____ Website: _____

Contact: _____ Email: _____

Serial #: _____

Or contact Convaid Customer Service at
844 US Mobility (844-876-6245) (+1-310-618-0111) or
convaidsales.us@etac.com

Warranty

Convoid warrants to the original retail purchaser of the Convoid product, that if any part thereof proves functionally defective in material or workmanship within the specified warranty period, such defective part will be repaired or replaced (at Convoid’s discretion) free of charge. Warranty service may be performed by Convoid service center or (at Convoid’s discretion) the factory.

Warranty Period

Frame Five years
Other components One year
Fabric & webbing One year
Sensiform cushion Two years

This warranty does not cover normal wear and tear or damage caused by accident or misuse. To exercise this limited warranty, the user should first obtain a Return Authorization Number from Convoid’s customer service. The product must be delivered charges pre-paid to the factory or to an authorized service center, together with a copy of the original invoice.

THIS LIMITED WARRANTY EXCLUDES ANY CLAIM FOR INCIDENTAL OR CONSEQUENTIAL DAMAGES. ANY IMPLIED WARRANTY APPLICABLE IS LIMITED TO THE DURATION OF THIS WRITTEN WARRANTY. SOME STATES DO NOT ALLOW THE EXCLUSION OR LIMITATIONS OF INCIDENTAL OR CONSEQUENTIAL DAMAGES OR LIMITATIONS ON HOW LONG AN IMPLIED WARRANTY LASTS, SO THE ABOVE LIMITATIONS OR EXCLUSIONS MAY NOT APPLY TO THE USER. THERE ARE NO WARRANTIES WHICH EXTEND BEYOND THE DESCRIPTION ON THE FACE THEREOF.

This warranty gives the user specific legal rights and the user may have other rights that vary from state to state. Warranty applicable in USA only, may vary in other countries.



Convoid Products, LLC

2830 California Street, Torrance, CA 90503, USA

Toll free in the US: 1-844-US-Mobility (844-876-6245) • Phone: (310) 618-0111 • Fax: (310) 618-8811

Email: convoidsales.us@etac.com • International Email: international.convoid.us@etac.com

www.etac.com

UG1201-ENG-Rev.03 2024-11-19
